

IO-DI8-TO8

I/O Expansion Module

8 Inputs, 8 Outputs

The IO-DI8-TO8 is an I/O expansion module that can be used in conjunction with specific Unitronics OPLC controllers.

The module offers 8 digital inputs, type pnp/npn (source/sink), and 8 pnp (source) transistor outputs.

The interface between the module and the OPLC is provided by an adapter.

The module may either be snap-mounted on a DIN rail, or screw-mounted onto a mounting plate.

Component identification

1	Module-to-module connector
2	Status indicators
3	Connection points for power supply to outputs
4	Output connection points
5	Module-to-module connector port
6	Input connection points

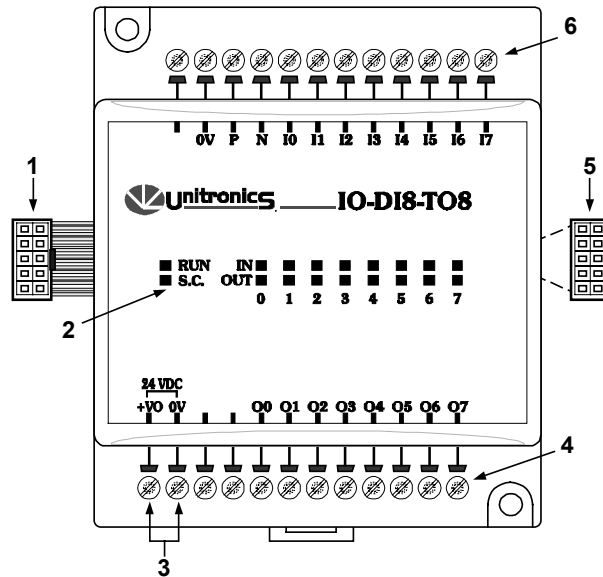

User safety and equipment protection guidelines

This document is intended to aid trained and competent personnel in the installation of this equipment as defined by the European directives for machinery, low voltage and EMC. Only a technician or engineer trained in the local and national electrical standards should perform tasks associated with the electrical wiring of this device.

- Under no circumstances will Unitronics be liable or responsible for any consequential damage that may arise as a result of installation or use of this equipment, and is not responsible for problems resulting from improper or irresponsible use of this device.
- All examples and diagrams shown in the manual are intended to aid understanding. They do not guarantee operation.
- Unitronics accepts no responsibility for actual use of this product based on these examples.
- Only qualified service personnel should open this device or carry out repairs.
- Please dispose of this product in accordance with local and national standards and regulations.



- Check the user program before running it.
- Do not attempt to use this device with voltage exceeding permissible levels.
- Install an external circuit breaker and take all appropriate safety measures against short-circuiting in external wiring.



- Failure to comply with appropriate safety guidelines can result in severe personal injury or property damage. Always exercise proper caution when working with electrical equipment.

Mounting the Module

Mounting Considerations

- Do not install in areas with: excessive or conductive dust, corrosive or flammable gas, moisture or rain, excessive heat, regular impact shocks or excessive vibration.
- Provide proper ventilation by leaving a minimum space of 10mm between the top and bottom edges of the device and the enclosure walls.
- Do not place in water or let water leak onto the unit.
- Do not allow debris to fall inside the unit during installation.

DIN-rail mounting

Snap the device onto the DIN rail as shown below; the module will be squarely situated on the DIN rail.

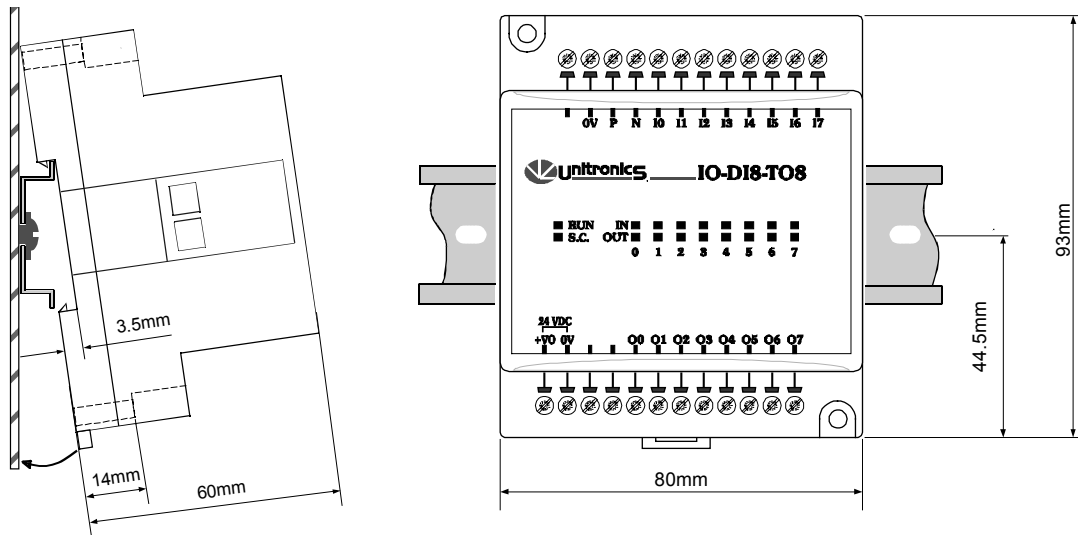

Screw-Mounting

The figure on the next page is drawn to scale. It may be used as a guide for screw-mounting the module.

Mounting screw type: either M3 or NC6-32.

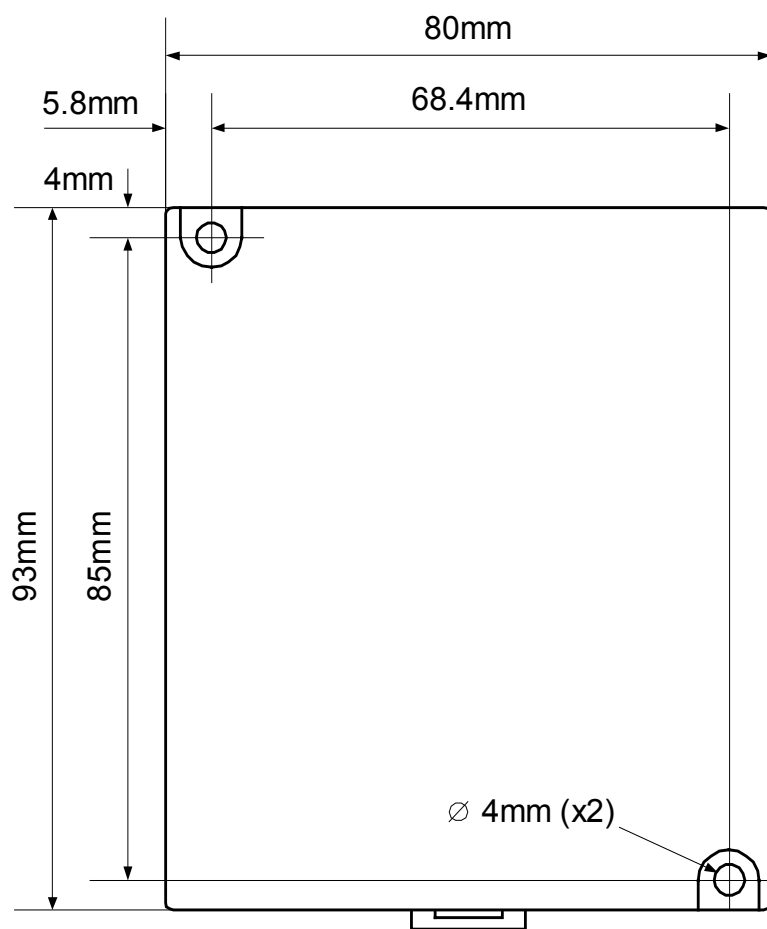

Connecting Expansion Modules

An adapter provides the interface between the OPLC and an expansion module. To connect the I/O module to the adapter or to another module:

- 1 Push the module-to-module connector into the port located on the right side of the device.

Note that there is a protective cap provided with the adapter. This cap covers the port of the **final** I/O module in the system.



- To avoid damaging the system, do not connect or disconnect the device when the power is on.

Component identification	
1	Module-to-module connector
2	Protective cap

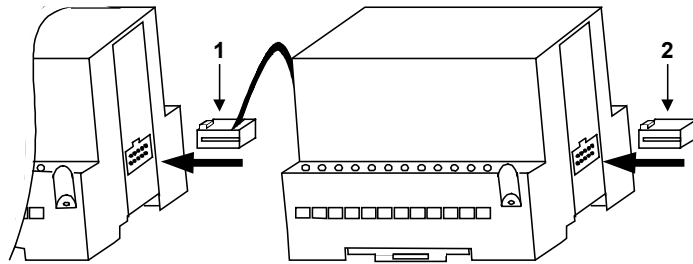

Wiring

Wire Size

Use 26-12 AWG wire (0.13 mm²–3.31 mm²) for all wiring purposes.

Wiring Considerations

- Note that the adapter and I/O signals must be connected to the same 0V signal.
- Do not use tin, solder or any other substance on the stripped wire that might cause the wire strand to break.
- We recommend that you use crimp terminals for wiring.
- Install at maximum distance from high-voltage cables and power equipment.

General Wiring Procedures

- 1 Strip the wire to a length of 7±0.5mm (0.250–0.300 inches).
- 2 Unscrew the terminal to its widest position before inserting a wire.
- 3 Insert the wire completely into the terminal to ensure that a proper connection can be made.
- 4 Tighten enough to keep the wire from pulling free.

To avoid damaging the wire, do not exceed a maximum torque of 0.5 N·m (5 kgf·m).



- Do not touch live wires.
- Double-check all the wiring before turning on the power supply.

- **I/O Wiring**

- Input or output cables should not be run through the same multi-core cable or share the same wire.
- Allow for voltage drop and noise interference with input/output lines used over an extended distance. Use wire that is properly sized for the load.

npn (sink) inputs

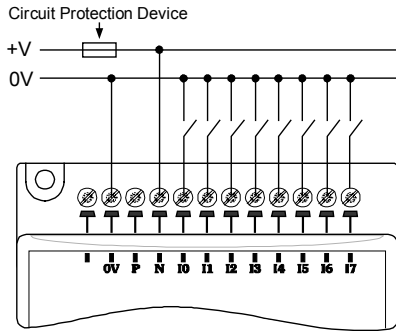

pnp (source) inputs

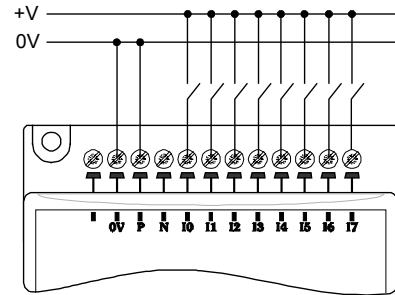

npn (sink)
high-speed counter/frequency measurer

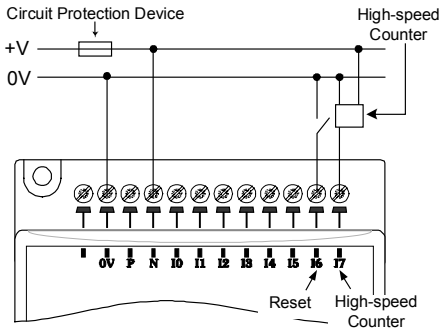

pnp (source)
high-speed counter/frequency measurer

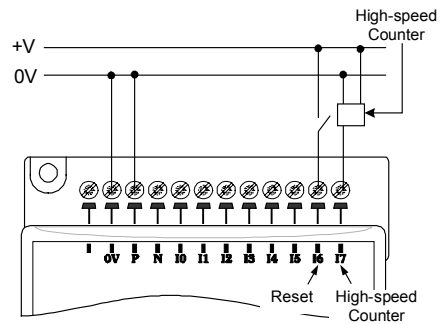

Wiring the Output's Power Supply

Wiring DC supply

1 Connect the "positive" cable to the "+V0" terminal, and the "negative" to the "0V" terminal.

- A non-isolated power supply can be used provided that a 0V signal is connected to the chassis.
- Do not connect the 'Neutral or 'Line' signal of the 110/220VAC to the device's 0V pin.
- In the event of voltage fluctuations or non-conformity to voltage power supply specifications, connect the device to a regulated power supply.

Outputs

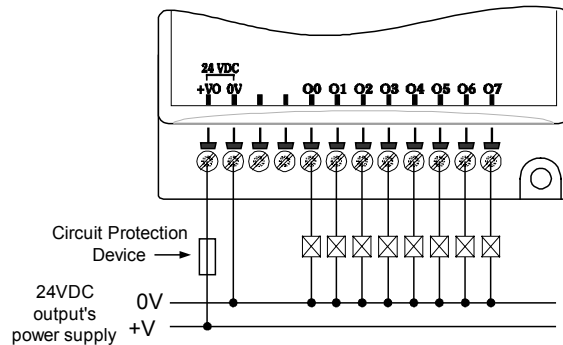

IO-DI8-TO8 Technical Specifications

Max. current consumption	70mA maximum from the adapter's 5VDC
Typical power consumption	0.15W @ 5VDC
Status indicator (RUN)	Green LED: —Lit when a communication link is established between module and OPLC. —Blinks when the communication link fails.

Inputs

Number of inputs	8 (in one group)
Input type	pnp (source) or npn (sink)
Galvanic isolation	None
Status indicators (IN)	Green LEDs—Lit when the corresponding input is active.
Nominal input voltage	24VDC
Input voltage	
pnp (source)	0-5VDC for Logic '0' 17-28.8VDC for Logic '1'
npn (sink), voltage/current	17-28.8VDC/<1.1 mA for Logic '0' 0-5VDC/>4.3mA for Logic '1'
Input current	4.5mA@24VDC
Response time	10mSec typical
Input #7	The specifications below apply when this input is wired for use as a high-speed counter input/frequency measurer. See Notes 1 and 2.
Resolution	16-bit
Frequency	5kHz maximum
Minimum pulse width	80µs

Outputs

Number of outputs	8 pnp (source)
Output type	P-MOSFET (open drain), 24VDC
Galvanic isolation	None
Output current	0.5A maximum (per output) Total current: 3A maximum (all outputs)
Maximum frequency	20Hz (resistive load) 0.5 Hz (inductive load)
Short circuit protection	Yes
Status Indicators	
(OUT)	Red LEDs—Lit when the corresponding output is active.
(S.C)	Red LED—Lit when an output is short-circuited.
Operating voltage	20.4 to 28.8VDC
Nominal operating voltage	24VDC

Environmental

IP20	
Operating temperature	0° to 50° C
Storage temperature	-20° to 60° C
Dimensions (WxHxD)	80mm x 93mm x 60mm
Weight	141g (4.9oz.)
Mounting	Either onto a 35mm DIN-rail or screw- mounted.

Notes:

- Input #7 can function either as a high-speed counter, a frequency measurer, or as a normal digital input. When Input #7 is used as a normal digital input, normal input specifications apply.
- Input #6 can function either as the counter's reset, or as a normal digital input; in either case, its specifications are those of a normal digital input.

Addressing I/Os on M90 Expansion Modules

Inputs and outputs located on I/O expansion modules that are connected into an M90 OPLC are assigned addresses that comprise a letter and a number. The letter indicates whether the I/O is an input (I) or an output (O). The number indicates the I/O's location in the system. This number relates to both the position of the expansion module in the system, and to the position of the I/O on that module.

Expansion modules are numbered from 0-7 as shown in the figure below.

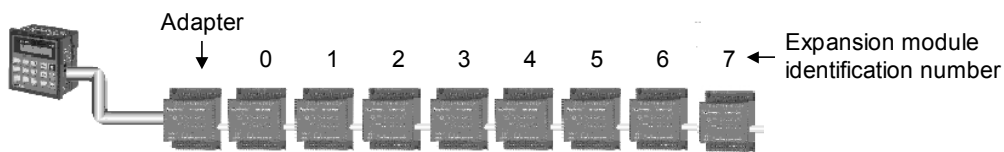

The formula below is used to assign addresses for I/O modules used in conjunction with the M90 OPLC.

X is the number representing a specific module's location (0-7). Y is the number of the input or output on that specific module (0-15).

The number that represents the I/O's location is equal to:

$$32 + x \cdot 16 + y$$

Examples

- Input #3, located on expansion module #2 in the system, will be addressed as I 67,
 $67 = 32 + 2 \cdot 16 + 3$
- Output #4, located on expansion module #3 in the system, will be addressed as O 84,
 $84 = 32 + 3 \cdot 16 + 4$.

EX90-DI8-RO8 is a stand-alone I/O module. Even if it is the only module in the configuration, the EX90-DI8-RO8 is always assigned the number 7.

Its I/Os are addressed accordingly.

Example

- Input #5, located on an EX90-DI8-RO8 connected to an M90 OPLC will be addressed as I 149, $149 = 32 + 7 \cdot 16 + 5$

8 Convenient I/O Expansion Modules

	Digital I/O (transistor)			Digital I/O (relay)			Analog I/O	PT 100
	IO-DI8-TO8*	IO-DI16*	IO-TO16*	IO-DI8-RO4*	IO-RO8*	EX90-DI8-RO8*	IO-AI4-AO2*	IO-PT4*
Digital inputs (24 VDC)	8 pnp/npn (source/sink)	16 pnp/npn (source/sink)	—	8 pnp/npn (source/sink)	—	8 pnp/npn (source/sink)	—	—
Analog inputs	—	—	—	—	—	—	4 inputs 0-10V, 0-20mA 4-20mA	4 PT100 -50°C-460°C
Analog input resolution	—	—	—	—	—	—	12 bit	12 bit
Digital outputs	8 pnp (source)	—	16 pnp (source)	4 relay outputs	8 relay outputs	8 relay outputs	—	—
Analog outputs	—	—	—	—	—	—	2 outputs +/-10V,0-20mA, 4-20mA	—
Analog output resolution	—	—	—	—	—	—	12 bit + sign	—
High speed counter/ Frequency measurement	one	one		one		one		

*Used in conjunction with EX-A1=Expansion adapter

To order the expansion module that best fits your system, contact your local distributor.
For a list of Unitronics distributors, check our website: <http://www.unitronic.com/contact.htm>